

# Metering Technology

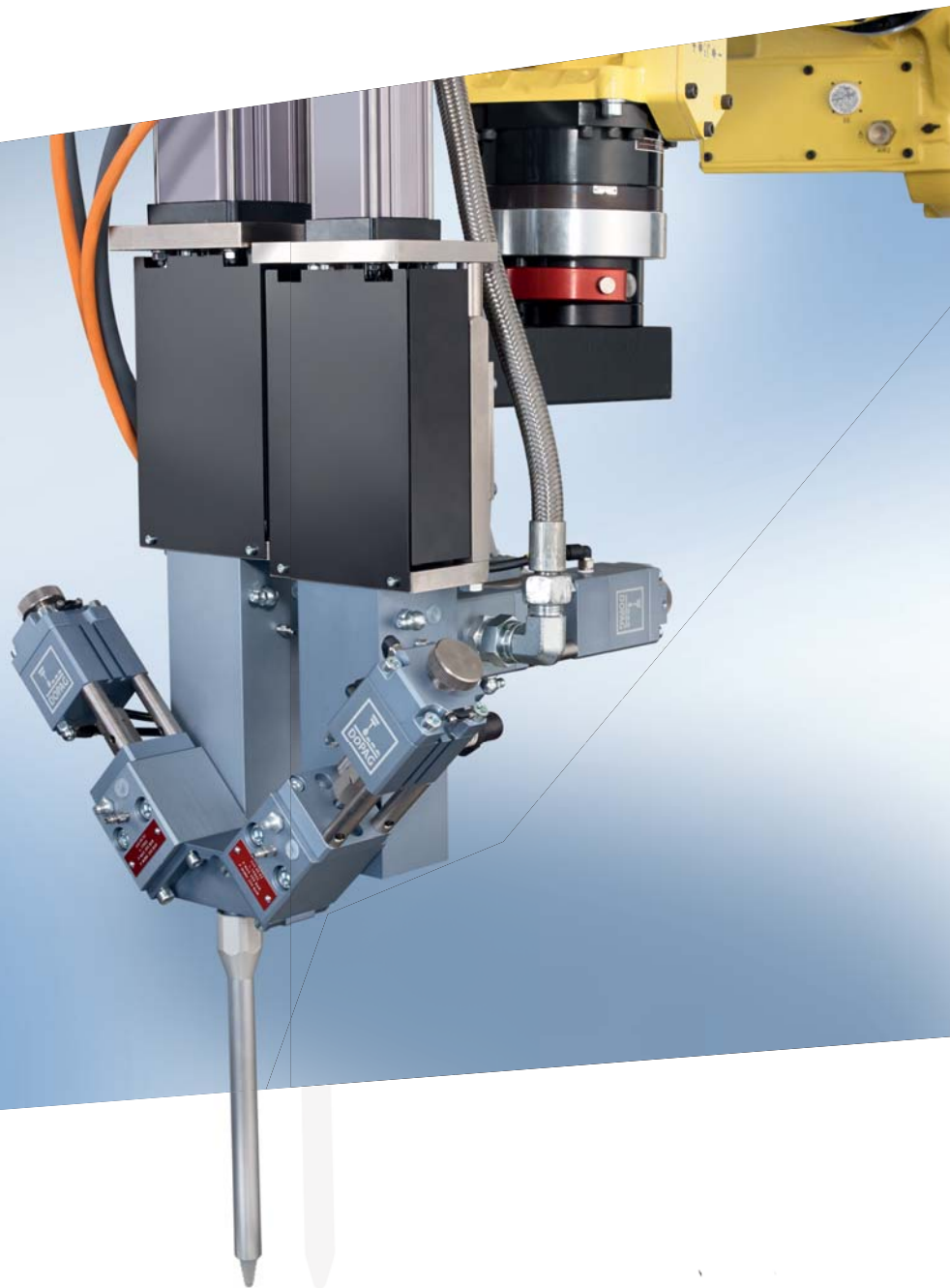

**vectodjs**

**vectomjx**



Hilger u. Kern / Dopag Group

**vectodis**

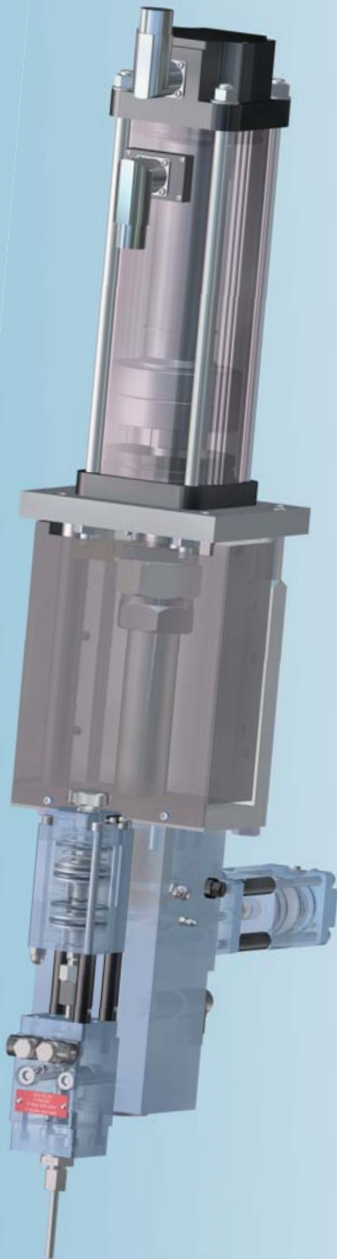

## General

To process low to high viscosity and even abrasive materials, the Hilger u. Kern / Dopag Group has developed two new product lines, vectodis and vectomix.

These new products are the result of consistent research, development and engineering with the goal of finding a visionary concept, able to set new standards for the future in metering technology.

The modular construction of vectodis and vectomix enables a wide range of use. Both product lines are especially recommended if a material needs to be applied in a high precision and repeatable way.

The rotational movement of a servo motor is converted into a linear movement by means of a spindle which is driving the steel piston.

Various constructional characteristics are resulting in minimal maintenance and reduced service intervals which leads to a longer product life.

## Industries

These modern metering systems can be used in any industry where materials need to be applied in a high precision and repeatable way.

- Automotive
- Electrical and electronic
- Renewable energy
- Aerospace
- White goods
- and many more

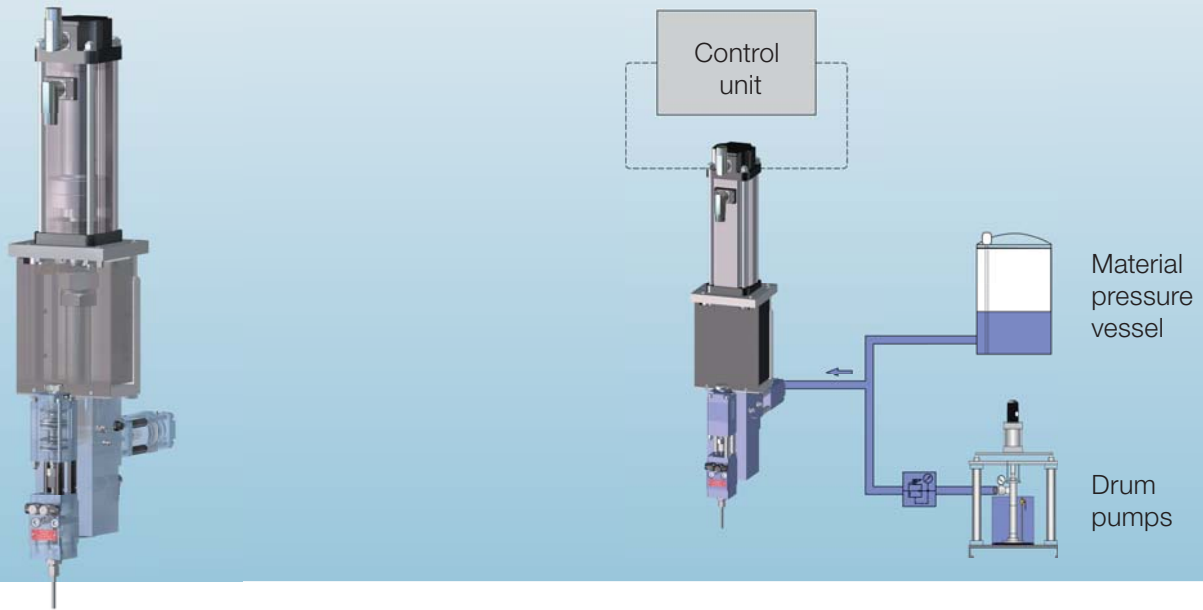

vectodis is used to handle single component materials. Just a suitable material supply and metering computer is required.

The material can be processed by either shot dispensing or continuous flow.

## Technical data

Size	Ø 6	Ø 10	Ø 20	Ø 36
Max. metering volume	1.8 ml	7.8 ml	31 ml	101 ml
Min. metering volume (5 mm stroke)	0.14 ml	0.4 ml	1.6 ml	5.1 ml
Metering stroke	65 mm	100 mm	100 mm	100 mm
Max. stroke speed*	100 mm/s	100 mm/s	100 mm/s	100 mm/s
Min. stroke speed*	0.1 mm/s	0.1 mm/s	0.1 mm/s	0.1 mm/s
Min. metering time (Full stroke)*	0.65 s	1.0 s	1.0 s	1.0 s
Min. cycle time (Full stroke)*	2.5 s	3.0 s	3.0 s	3.0 s
Max. supply pressure	160 bar	160 bar	100 bar	100 bar
Min. supply pressure	3 bar	3 bar	3 bar	3 bar
Max. working pressure	160 bar	160 bar	100 bar	100 bar
Viscosity range	50 -1,000,000 mPa s	50 -1,000,000 mPa s	50 -1,000,000 mPa s	50 -1,000,000 mPa s
Power supply	100 - 240 VAC/N/PE 3 x 220 VAC/PE 3 x 400 VAC/N/PE	100 - 240 VAC/N/PE 3 x 220 VAC/PE 3 x 400 VAC/N/PE	100 - 240 VAC/N/PE 3 x 220 VAC/PE 3 x 400 VAC/N/PE	100 - 240 VAC/N/PE 3 x 220 VAC/PE 3 x 400 VAC/N/PE
Max. dimensions	102 x 320 x 596 mm	116 x 365 x 759 mm	116 x 365 x 769 mm	150 x 390 x 858 mm
Weight	approx. 9.3 kg	approx. 11.8 kg	approx. 14.9 kg	approx. 26.9 kg

\* Depending on material characteristic, material supply pressure and use of the material compression function

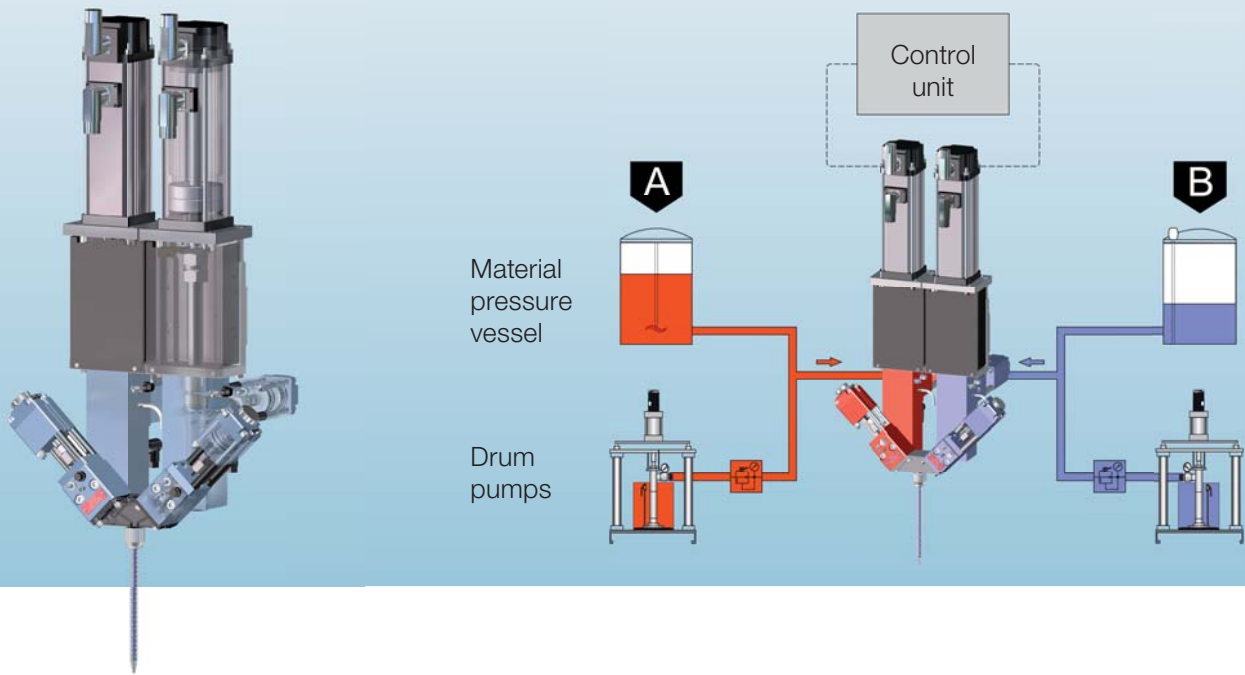

vectomix is used to handle multi component materials. Due to its compatibility and modularity, two vectodis single component piston metering systems with equal or different sizes are used. They can be connected by simply using a mixing block onto the outlet of which a disposable plastic mixer is mounted.

Just a suitable material supply and metering computer is required.

The material can be processed by either shot dispensing or continuous flow.

## Technical data

Size	Ø 6/6	Ø 10/10	Ø 20/20	Ø 36/36
Max. metering volume	3.7 ml	15.7 ml	62 ml	203 ml
Min. metering volume (5 mm stroke)	0.3 ml	0.8 ml	3.2 ml	10.2 ml
Metering stroke	65 mm	100 mm	100 mm	100 mm
Max. stroke speed*	100 mm/s	100 mm/s	100 mm/s	100 mm/s
Mixing ratio*	100:100 to 100:5 (lower on request)	100:100 to 100:5 (lower on request)	100:100 to 100:5 (lower on request)	100:100 to 100:5 (lower on request)
Min. metering time (Full stroke)*	0.65 s	1.0 s	1.0 s	1.0 s
Min. cycle time (Full stroke)*	2.5 s	3.0 s	3.0 s	3.0 s
Max. supply pressure	160 bar	160 bar	100 bar	100 bar
Min. supply pressure	3 bar	3 bar	3 bar	3 bar
Max. working pressure	160 bar	160 bar	100 bar	100 bar
Viscosity range	50 -1,000,000 mPa s	50 -1,000,000 mPa s	50 -1,000,000 mPa s	50 -1,000,000 mPa s
Power supply	100 - 240 VAC/N/PE 3 x 220 VAC/PE 3 x 400 VAC/N/PE	100 - 240 VAC/N/PE 3 x 220 VAC/PE 3 x 400 VAC/N/PE	100 - 240 VAC/N/PE 3 x 220 VAC/PE 3 x 400 VAC/N/PE	100 - 240 VAC/N/PE 3 x 220 VAC/PE 3 x 400 VAC/N/PE
Max. dimensions	415 x 350 x 544 mm	415 x 365 x 709 mm	415 x 365 x 719 mm	449 x 390 x 825 mm
Weight	approx. 19.3 kg	approx. 24.3 kg	approx. 30.3 kg	approx. 55.3 kg

\* Depending on material characteristic, material supply pressure and use of the material compression function

## Application areas

- Bonding
- Sealing
- Moulding
- Encapsulation
- Shot dispensing
- Bead dispensing

## Features and Benefits

- Modular construction enables a wide range of use, variable mixing ratios and flow rates
- Metering unit with a snuff back effect avoids the contamination of the work space
- High precision through metering and mixing at the point of application
- Dispensing multi shots with a single metering chamber volume enables short cycle times
- High process security through:
  - construction with reduced dead space
  - de-airing on the top of the metering chamber
  - metering chamber with pressure monitoring
- Reduction of the maintenance through:
  - specially guided metering pistons
  - coupling between drive and metering piston
  - flushing of the metering piston with sealing liquid

## Control unit

### Hilger u. Kern metering computer

To control these systems a metering computer with touch screen terminal is used.

With this metering computer all applications that can be achieved with vectodis or vectomix can be parameterised and different metering processes can be memorised.

The control unit is wired into a control cabinet.

The metering computer can also handle applications where a speed proportional material supply is required, for example in combination with a robot.

**vectomix**

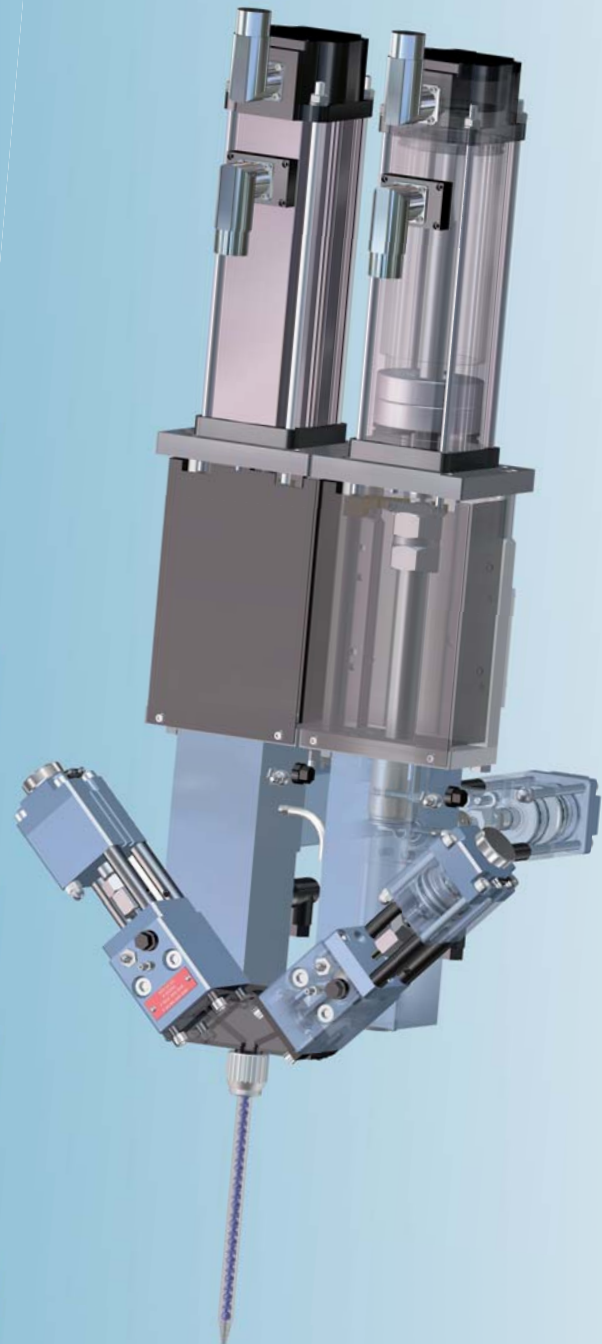

# Hilger u. Kern / Dopag Group

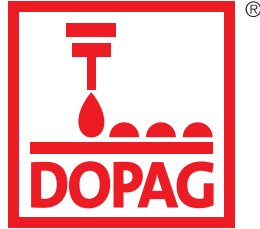

The Hilger u. Kern / Dopag Group, with more than 250 employees, is one of the leading manufacturers of metering and mixing systems in the world for plural component polymers and single component media such as greases, oils and pastes.

## Germany

Hilger u. Kern GmbH  
Industrietechnik  
Käfertaler Straße 253  
68167 Mannheim

☎ +49 621 3705-0  
📠 +49 621 3705-200  
info@hilger-kern.de  
www.hilger-kern.com

## Switzerland

DOPAG Dosiertechnik  
und Pneumatik AG  
Langackerstrasse 25  
6330 Cham

☎ +41 41 7855-757  
📠 +41 41 7855-700  
info@dopag.ch  
www.dopag.com

For more than 35 years the group, with subsidiaries and distributors in over 30 countries, has developed systems and components to suit your individual needs.

## Subsidiaries

### France

DOPAG Sarl  
contact@dopag.fr

### United Kingdom

DOPAG (UK) Ltd.  
uksales@dopag.co.uk

### Italy

DOPAG ITALIA S.r.l.  
info.it@dopag.com

### India

DOPAG India Pvt Ltd.  
info@dopag.in

### USA

DOPAG (US) Ltd.  
ussales@dopag.com

### China

DOPAG (Shanghai) Metering  
Technology Co., Ltd.  
office@dopag.cn

Please visit our internet page to find the contact data of your local partner (Sales and Service Organisation).